



# FUEL PRESSURE REGULATORS FPR SERIES

## WHAT IS A FUEL PRESSURE REGULATOR?

A fuel pressure regulator's job is to maintain constant fuel pressure above the intake manifold pressure.

## WHEN DO YOU NEED TO INSTALL ONE?

The installation of performance fuel injectors or a high-flow fuel pump requires the use of an aftermarket fuel pressure regulator to allow pressure adjustments while maintaining a stable base pressure. They can also be used to maximise a standard fuel system's ability to cope with minor power modifications.

## WHY BUY A TURBOSMART FPR?

All Turbosmart FPRs are manufactured from billet aluminium and hand-assembled to ensure maximum precision. Turbosmart FPR's have been designed to provide smooth and stable fuel pressure delivery under all conditions from idle to full throttle and are suitable for use with both electric and mechanical fuel pumps.

The FPR range features an easy screw and lock adjustment and provide a stable 1:1 ratio between fuel pressure and manifold pressure. Each FPR is backed by a variety of accessories such as fuel rail adapters and fittings to suit most popular makes and models.

The diagram below shows a common Fuel Pressure Regulator setup: inlet port connected to the fuel rail, return port to the fuel tank and the Vacuum/Pressure fitting to the inlet manifold.

The base pressure is adjusted via a screw-and-nut system located on top of the fuel pressure regulator.

Thinking Fuel Pressure Regulators? Think Turbosmart.

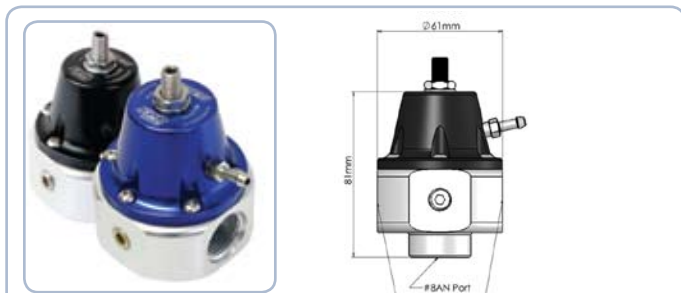
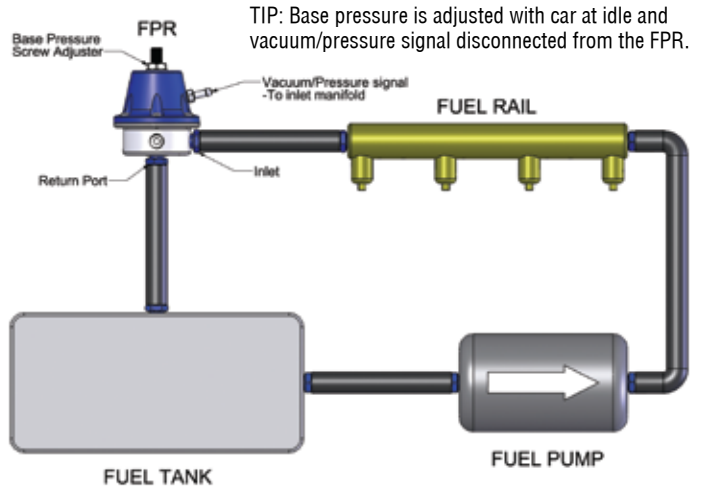

### FPR-3000

Ideal for street/race cars with up to 3000hp fuel systems. Features special internals to handle all types of race fuels. -10AN inlet ports, -8AN outlet port, 1/8 NPT gauge port, 30-70 PSI base pressure adjustments, 1:1 ratio. Supplied with a mounting bracket, vacuum nipple, gauge port blank and a -3AN vacuum/pressure port adapter.

BLUE: TS-0401-1007  
BLACK: TS-0401-1008

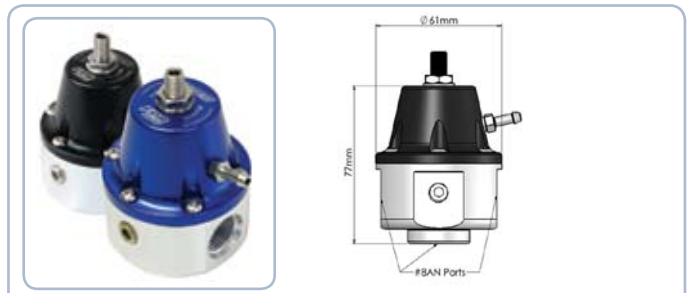

### FPR-2000

Ideal for street/race cars with up to 2000hp fuel systems. Features special internals to handle all types of race fuels. -8AN inlet and outlet ports, 1/8 NPT gauge port 30-70 PSI base pressure adjustments, 1:1 ratio. Supplied with a mounting bracket, vacuum nipple, gauge port blank and a -3AN vacuum/pressure port adapter.

BLUE: TS-0401-1005  
BLACK: TS-0401-1006

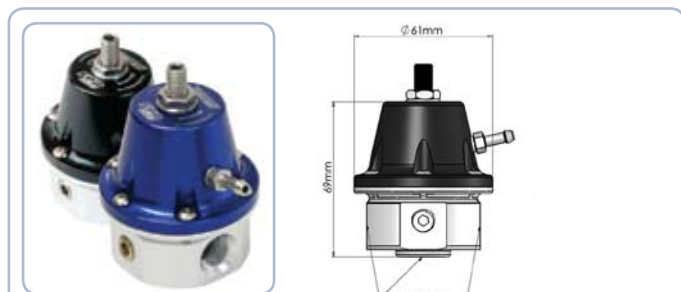

### FPR-1200

Ideal for street/race cars with up to 1200hp fuel systems. Features special internals to handle all types of race fuels. -6AN inlet and outlet ports, 1/8 NPT gauge port, 30-70 PSI base pressure adjustments, 1:1 ratio. Supplied with a mounting bracket, vacuum nipple and a gauge port blank.

BLUE: TS-0401-1003  
BLACK: TS-0401-1004

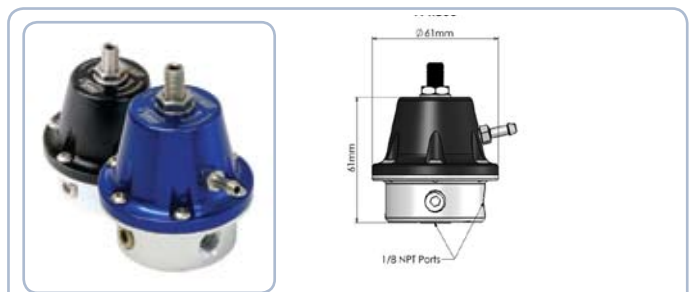

### FPR-800

Ideal for modified street cars with up to 800hp fuel systems using pump fuel. Features 1/8 NPT inlet and outlet ports, 1/8 NPT gauge port, 30-70 PSI base pressure adjustments, 1:1 ratio. Supplied with a mounting bracket, vacuum nipple and a gauge port blank.

BLUE: TS-0401-1001  
BLACK: TS-0401-1002



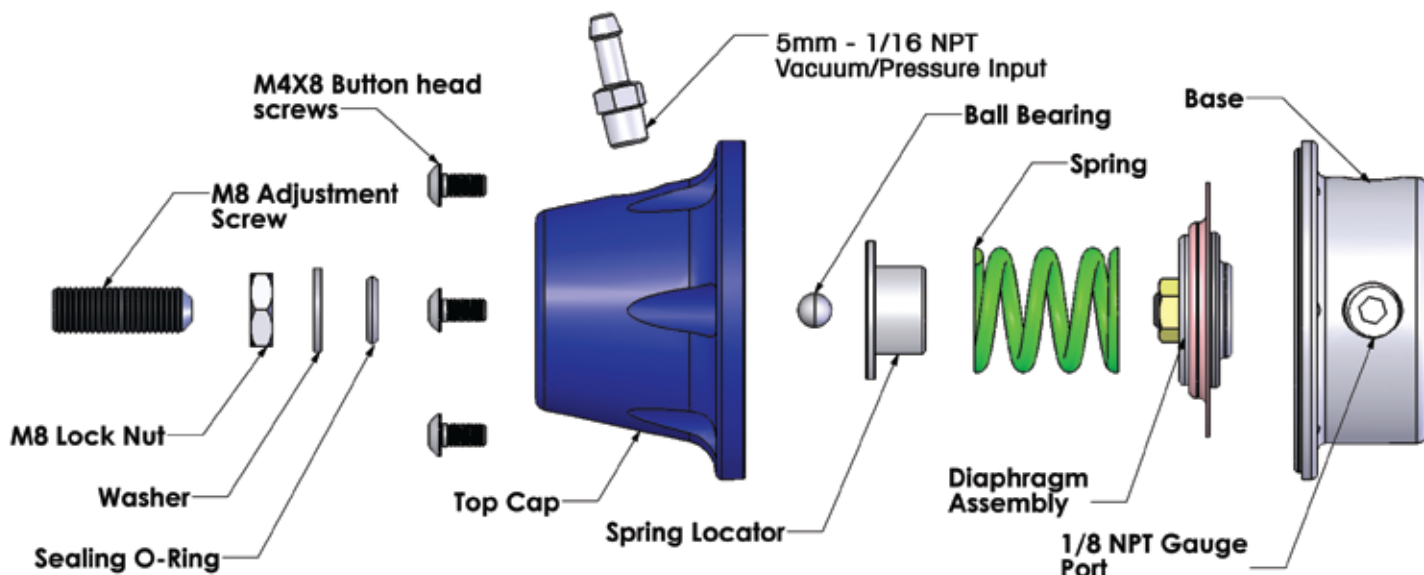

## ACCESSORIES AND SPARES

Fuel Pressure Gauge - Liquid Filled, 0-100 psi 1/8 NPT Fitting	TS-0402-2023
FPR 800 Replacement Diaphragm Assembly	TS-0401-3001
FPR 1200 Replacement Diaphragm Assembly	TS-0401-3002
FPR 2000 and 3000 Replacement Diaphragm Assembly	TS-0401-3003
FPR 800 Fuel Fitting Kit 1/8 NPT to 6mm hose tail	TS-0402-1107
FPR Fuel Fitting Kit 1/8 NPT to 8mm hose tail	TS-0402-1108
FPR 800 Fuel Fitting Kit 1/8 NPT to 10mm hose tail	TS-0402-1115
FPR 800 Fuel Fitting Kit 1/8 NPT to -6 AN male	TS-0402-1112
FPR 1200 Fuel Fitting Kit -6 AN to 6mm hose tail	TS-0402-1109
FPR 1200 Fuel Fitting Kit -6 AN to 8mm hose tail	TS-0402-1110
FPR 1200 Fuel Fitting Kit -6 AN to 10mm hose tail	TS-0402-1116
FPR 1200 Fuel Fitting Kit -6 AN to -6 AN male	TS-0402-1111

Please Note: Kits are supplied with 3 hose fittings and blanking plug in the specified size

Fuel Rail Adapter -Subaru/Nissan/Mazda	TS-0402-1001
Fuel Rail Adapter - Toyota/Subaru	TS-0402-1002
Fuel Rail Adapter - Toyota/Mazda	TS-0402-1003
Fuel Rail Adapter - Honda	TS-0402-1004
Fuel Rail Adapter - Mitsubishi	TS-0402-1005
Fuel Rail Adapter - Audi/VW	TS-0402-1006
Fuel Rail Adapter - Subaru (STI 08)	TS-0402-1013
Fuel Rail Adapter -Mitsubishi (EVO X)	TS-0402-1014

Please Note: All Fuel Rail Adapters have 1/8 NPT port

## FUEL RAIL ADAPTER FITTING GUIDE

MAKE	MODEL/ENGINE	FUEL RAIL ADAPTER
Mazda	13BREW = FD3S RX7 Series 6	TS-0402-1001
Mazda	13B = RX7 Series 4	TS-0402-1003
Mitsubishi	4G63 = Evo 4, 5, 6, 7, 8, 9	TS-0402-1005
Mitsubishi	4B11T = EVO 10	TS-0402-1014
Nissan	SR20DET = S13, S14, S15 SILVIA	TS-0402-1001
Nissan	RB26DETT = BNR32, BNR33, BNR34 GTR	TS-0402-1001
Nissan	RB25DETT = HCR32, ECR33, ER34 SKYLINE	TS-0402-1001
Subaru	EJ20 = GC8 WRX before Bug Eye	TS-0402-1001
Subaru	EJ25 = WRX 08" Onwards (Not STI)	TS-0402-1001
Subaru	EJ25 = Liberty 05" Onwards	TS-0402-1001
Subaru	EJ25 = Forester 08" Onwards	TS-0402-1001
Subaru	EJ20 = GDA WRX Bug Eye onwards	TS-0402-1002
Subaru	EJ25 = WRX STI 08"	TS-0402-1013
Toyota	2JZGTE = JZ80 SUPRA, JZS147 ARISTO	TS-0402-1002
Toyota	4EFTE = EP STARLET	TS-0402-1002
Toyota	4AGZE	TS-0402-1002
Toyota	4AGE	TS-0402-1002
Toyota	3SGTE = MR2, CELICA GT4	TS-0402-1003
Toyota	1UZ-FE Lexus/ Soarer V8	TS-0402-1003
Toyota	1JZGTE = SUPRA, CRESTA, CHASER, MARK II	TS-0402-1003
Honda	B16A = EG6 CIVIC SIR, EK4 CIVIC, CRX DEL SOL	TS-0402-1004
Honda	B16B = EK9 CIVIC TYPE R	TS-0402-1004
Audi/VW	All models using Bosch adapters	TS-0402-1006
Ford	BA, BF, FG XR6 Turbo and Territory Turbo	TS-0402-1006